

UNLESS OTHERWISE SPECIFIED: DIMENSIONS ARE IN MILLIMETERS SURFACE FINISH: TOLERANCES: LINEAR: ANGULAR:		FINISH: HRC:	DEBUR AND BREAK SHARP EDGES	DO NOT SCALE DRAWING	REVISION
PROJECT NAME:				<p style="text-align: center;">SUBEC AB</p> <p style="text-align: center;">Non Adj.Roll.Cross, Ø12, Ø33, 2xØ44 HRX</p>	
PROJECT NO:					
NAME	SIGNATURE	DATE		<p style="text-align: center;">TITLE:</p>	
DRAWN Sts		2024-11-05			
MATERIAL:			ARTICLE NO: 10469A	DWG NO. 3-400956-00_10469A	A4
Q.A			WEIGHT: 2462.9g	SCALE: 1:2	SHEET 1 OF 2 10469A

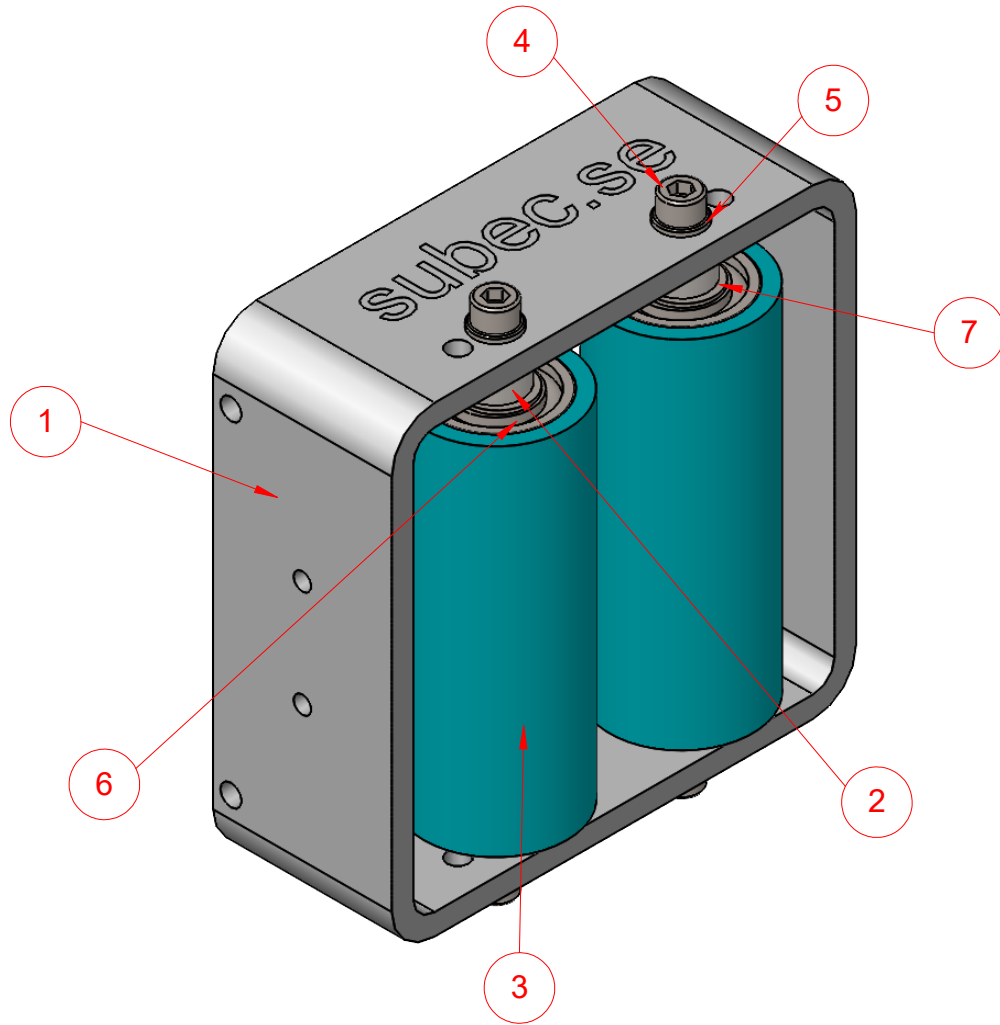

ITEM NO.	PART NUMBER	DESCRIPTION	QTY.
1	10469P1A	Cross Body 130x130	1
2	58391	Shaft for D40 L100 Hor M6x12	2
3	78383	Cylinder D40 L100 HRX Sim	2
4	DIN 912 M6 x 16 --- 16N		4
5	Washer DIN 125 - B 6.4		4
6	DIN 625 - 6002 - 12,SI,NC,12_68		4
7	Circlip DIN 471 - 15 x 1		4

UNLESS OTHERWISE SPECIFIED: DIMENSIONS ARE IN MILLIMETERS SURFACE FINISH: TOLERANCES: LINEAR: ANGULAR:		FINISH:	DEBUR AND BREAK SHARP EDGES	DO NOT SCALE DRAWING	REVISION
PROJECT NAME:		HRC:		SUBEC AB	
PROJECT NO:				TITLE: Non Adj.Roll.Cross, Ø12, Ø33, 2xØ44 HRX	
NAME	SIGNATURE			DATE	
DRAWN	Sts		2024-11-05		
MATERIAL:		ARTICLE NO: 10469A		DWG NO. 3-400956-00_10469A	
Q.A		WEIGHT:	2462.9g	SCALE: 1:2	SHEET 2 OF 2
					A4 10469A